

EPA BlowVac Special

MUNTZ 555-ESD-S GS

SPECIAL FIELD SERVICE & EPA BLOWVAC TO REMOVE DUST AND DEBRIS FROM ADVANCED ELECTRONIC EQUIPMENT HIGHLY SENSITIVE TO DUST AND STATIC BUILD UP IN FIELDS AS TELECOM, OFFICE AUTOMATION, SCIENTIFIC, MEDICAL AND SEMICONDUCTOR & ELECTRONICS INDUSTRIES REQUIRING TOP LEVEL "ELECTRONIC CARE".

- ✓ "BLOWVAC" = BLOWER AND VACUUM CLEANER IN ONE !
- ✓ NO CARRYING NOR INVESTMENT MULTIPLE APPLIANCES.
- ✓ SUPERB SUCTION- & BLOWPOWER AT LOW ELECTRICITY CONSUMPTION (COST) BY USE HIGH EFFICIENCY MOTOR !
- ✓ GENTLE CONTROLLED ESD-SAFE STATIC DISCHARGE ON TIP BLOW/VACUUM NOZZLES TO EARTH POWER OUTLET.
- ✓ FULLY EPA COMPLIANT TO IEC 61340-5-1 !
- ✓ TOP QUALITY ELECTRICAL & ELECTRONIC PARTS FOR UTMOST RELIABILITY AND GLOBAL USE.
- ✓ THERMAL CUT-OUT & RFI/EMC FILTER EQUIPED.
- ✓ DURABLE COMPACT HOUSING.

- ✓ EPA HOSE ASSEMBLY EXTENDING FULL 130CM.
- ✓ EPA BLOW & VACUUM HARD CREVICE NOZZLE AND SOFT RUBBER NOZZLE. LEATHER SHOULDERSTRAP.
- ✓ SPECIAL 1,2 LITRE MULTILAYER FILTERBAG.
- ✓ ADVANCED 5-STAGE (PRE-MOTOR) FILTER SYSTEM.
- ✓ DETACHABLE 3 METER TOP QUALITY CORDSET.

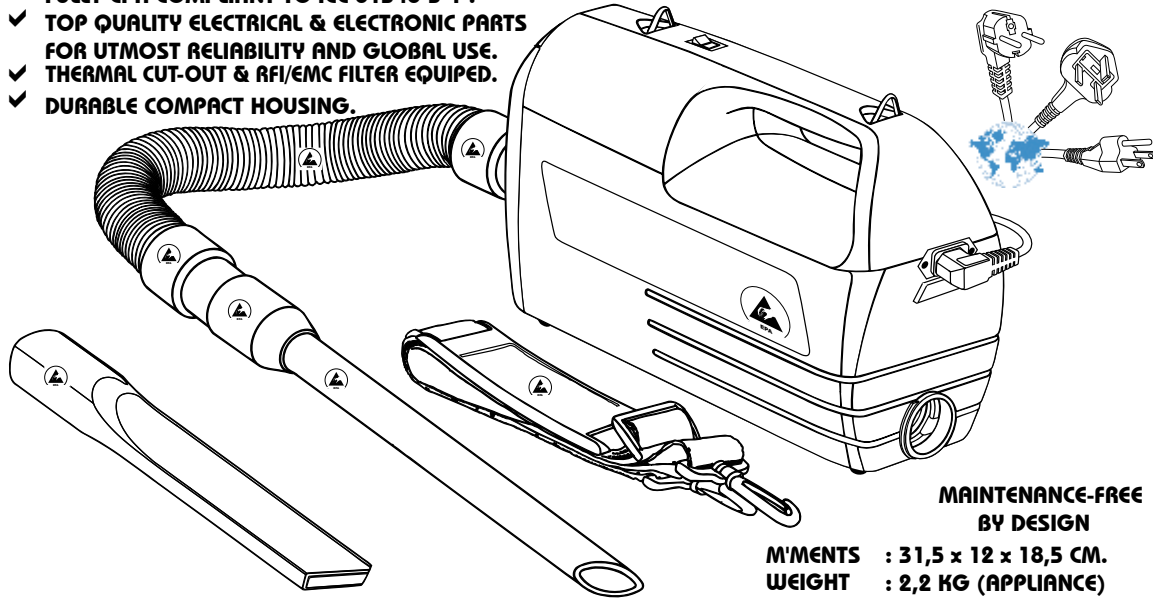

MAINTENANCE-FREE
BY DESIGN

MEASUREMENTS : 31,5 x 12 x 18,5 CM.
WEIGHT : 2,2 KG (APPLIANCE)

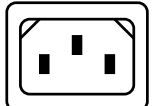

EPA BlowVac Special Electronic MUNTZ 555-ESD-S-E GS

ELECTRONIC "SILENT" VERSION.

- ✓ FULL SUCTION, BLOWPOWER, NOISE LEVEL CONTROL.
- ✓ DIAL LABEL TO FACILITATE PRECISION DUST REMOVAL.
- ✓ ENABLES LOW NOISE USE WHILST RETAINING AMPLE SUCTION & BLOWPOWER.

OPTIONAL :

- STEEL CABLE BRACKET VERSION C/W 10MM GROUNDING STUD (CB)
- EXTRA LONG CORDSET.
- HEPA (PRE-MOTOR) MICROFILTER
- 120V 50/60Hz AMERICAS SERIES.

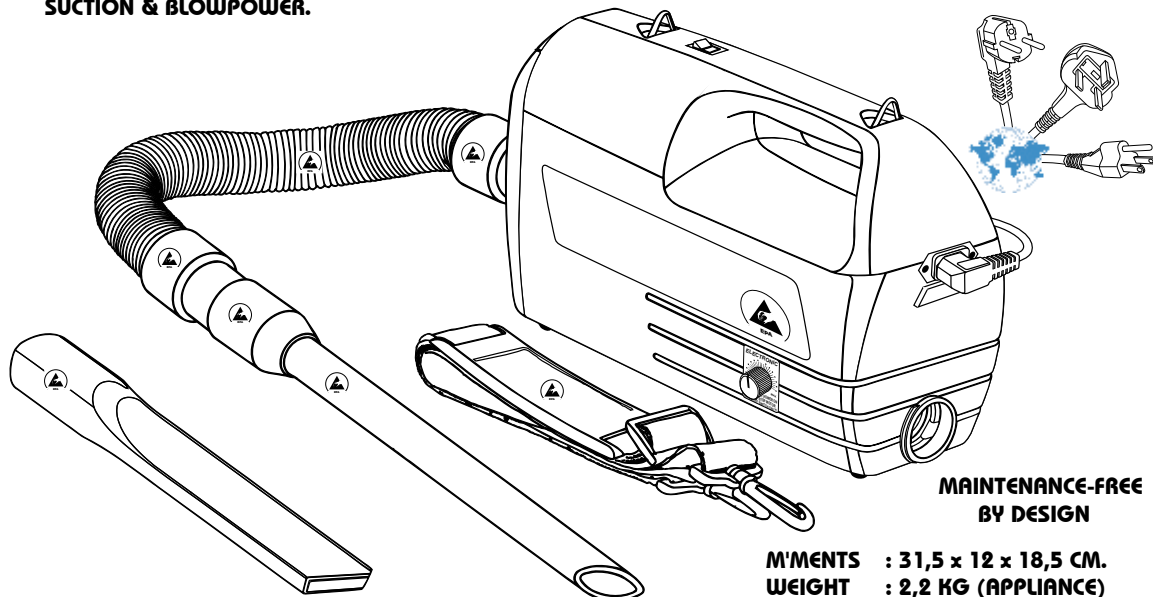

MAINTENANCE-FREE
BY DESIGN

MEASUREMENTS : 31,5 x 12 x 18,5 CM.
WEIGHT : 2,2 KG (APPLIANCE)

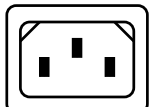

IEC 61340-5-1 = EPA = Electrostatic Protected Area, solely permitting use totally ESD safe materials and production aids to fully protect ESD sensitive electronics against harmful electrostatic discharges.



MUNTZ TECHNICS BV RESERVES THE RIGHT TO CHANGE, ALTER OR MODIFY IT'S APPLIANCES, REPLACEMENT PARTS, ACCESSORIES, OR THEIR PACKAGING, WITHOUT PRIOR NOTICE, EXCEPTING THOSE WITHIN SPECIFIC SUPPLY CONTRACT ARRANGEMENTS.

Manufactured In The Netherlands to European Community Standards No. 2006/95/EC & 2004/108/EC

Fabrique en Pays-Bas conformement aux normes de la communite Europeenne 2006/95/CEE & 2004/108/CEE.

Hergestellt in Holland nach normen der EG 2006/95/EWG & 2004/108/EWG.

Fabricado en Holanda de conformidad con las normas comunitarias Europeas 2006/95/CEE y 2004/108/CEE.

WALBOM A/S











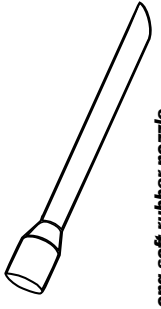

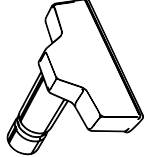
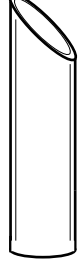

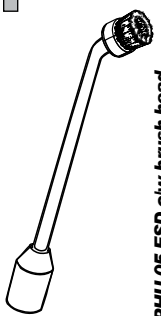
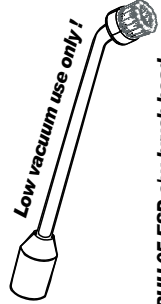

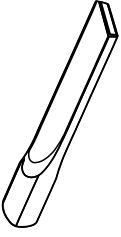
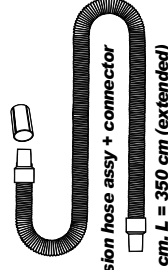
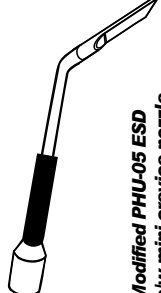
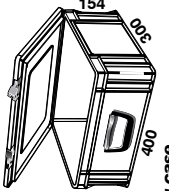
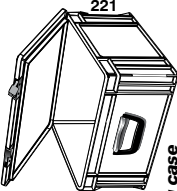
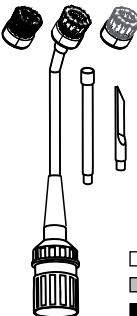
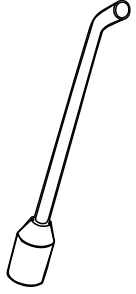
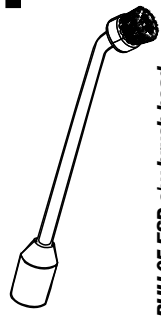
Amager Landevej 246 · DK-2770 Kastrup · Denmark · Tel. +45 32 46 11 60 · walbom@walbom.dk

WWW.WALBOM.DK

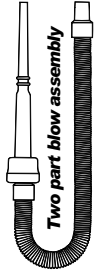
EPA ACCESSORIES 555 EPA BLOWVAC SERIES

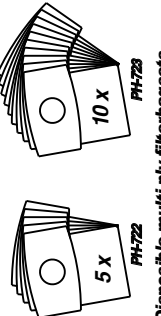
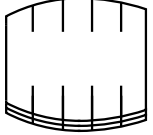

Cleaning related attachments (except blow assemblies) suit both vacuum & blower use !

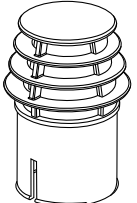
<p>PHU-20 ESD</p>  <p>Long soft rubber nozzle</p>	<p>PHU-22 ESD</p>  <p>Small moulded upholstery nozzle</p>	<p>PHU-23 ESD</p>  <p>Large aluminium upholstery nozzle</p>	<p>PHU-26 ESD</p>  <p>Soft rubber bulk pick up nozzle L = 150 mm. ID = 32 mm.</p>	<p>PHU-27 ESD</p>  <p>Swivel action alu floor nozzle with removable brush. Width 330 mm.</p>	<p>PHU-28 ESD</p>  <p>Fully (both in- and outside) electroplated steel Special mini extension rod set (3 x rod)</p>
<p>PHU-08 ESD</p>  <p>PHU-05 ESD ciw brush head</p>	<p>PHU-09 ESD</p>  <p>Low vacuum use only ! PHU-05 ESD ciw brush head</p>	<p>■ PHU-11 ESD ■ PHU-12 ESD □ PHU-13 ESD</p>  <p>D-Shape brush nozzle</p>	<p>PHU-16 ESD</p>  <p>Crevice nozzle</p>	<p>PHU-18 ESD</p>  <p>Extension hose assy + connector L = 85 cm. L = 350 cm (extended)</p>	<p>PHU-19 ESD</p>  <p>Modified PHU-05 ESD ciw mini crevice nozzle</p>
<p>PH-710 ESD</p>  <p>Carrying case</p>	<p>PH-711 ESD</p>  <p>Carrying case</p>	<p>BRUSH GUIDE</p> <p>Brush hardness : ■ MEDIUM/HARD (indicative) □ MEDIUM □ VERY SOFT</p>	<p>PHU-04 ESD</p>  <p>Mini attachment set</p>	<p>PHU-05 ESD</p>  <p>Long soft rubber nozzle</p>	<p>PHU-07 ESD</p>  <p>PHU-05 ESD ciw brush head</p>
<p>PH-707 ESD</p>  <p>Replacement hose assembly</p>	<p>PH-707L ESD</p>  <p>DOUBLE LENGTH Replacement hose assembly L = 85 cm. L = 300 cm (extended).</p>	<p>PH-707 ESD XL</p>  <p>SUPER STRETCH Replacement hose assembly L = 160 cm. L = 800 cm (extended).</p>	<p>PH-708 ESD</p>  <p>Two part blow assembly L = 70 cm. L = 200 cm (extended).</p>	<p>PH-708L ESD</p>  <p>Two part blow assembly (long) L = 105 cm. L = 380 cm (extended).</p>	<p>PH-709</p>  <p>Compact carrying bag.</p>
<p>PH-722 PH-723</p>  <p>Disposable multi-ply filterbagsets</p>	<p>PH-725</p>  <p>MICROMOTORFILTER Electrostatic charged filtermedia</p>	<p>PH-726</p>  <p>MICROMOTORFILTER (SANDWICH) HEPA H13 + Electrostatic charged filtermedia</p>	<p>PH-727</p>  <p>MICROMOTORFILTER (SANDWICH) HEPA H13 + Activated carbon filtermedia</p>	<p>PH-705 ESD</p>  <p>Medical exit air filter</p>	<p>PH-706</p>  <p>Deflects exit air in favoured direction NOT ESD-SAFE ! Exit air deflector</p>